



Cowboy Firepit & Grill

Owner's Manual

Assembly and Operating Instructions

Model # SC2042506-BA

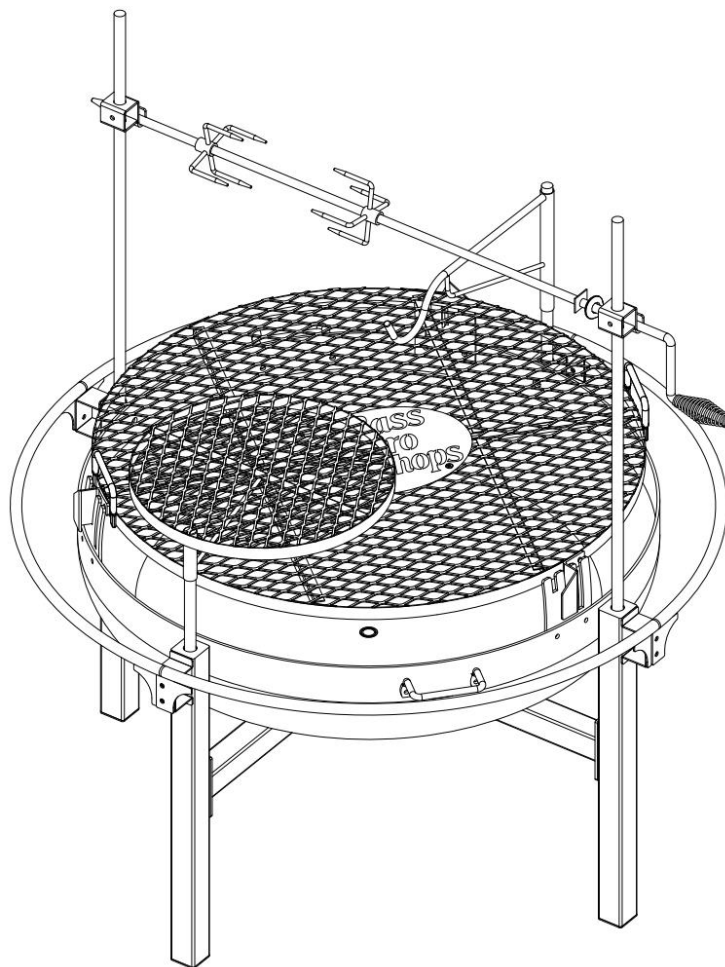

Tools required for assembly: (Not Included) Pliers, Philips & Flathead Screwdrivers, Adjustable Wrench.

Keep this manual for future reference.

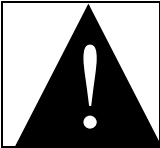

WARNING



- **Only** use this grill on a **hard, level, non-combustible, stable surface** (concrete, ground, etc.) capable of supporting the weight of the grill. Never use on wooden or other surfaces that could burn.
 - When grill is in use, keep **clearance of 36"** between the hot grill and any **combustible materials**, such as bushes, trees, wooden decks, wooden fences, buildings, etc. **Do not** place hot grill under **roof overhang** or in any other **enclosed area**.
 - For **outdoor use only**. **Do not operate** grill indoors or **in an enclosed area**.
 - For **household use only**. Do not use this grill for other than its intended purpose.
 - We recommend the use of a charcoal chimney starter to avoid the dangers associated with charcoal lighting fluid. If you choose to use charcoal lighting fluid, **only use lighting fluid approved for lighting charcoal**. Carefully read manufacturer's warnings and instructions on the charcoal lighting fluid and charcoal prior to the use of their product. Store charcoal lighting fluid safely away from grill.
 - When using charcoal lighting fluid, allow charcoal to burn until covered with a light ash (approximately 20 minutes). This will allow charcoal lighting fluid to burn off. Failure to do this could trap fumes from charcoal lighting fluid in grill and may result in **a flash fire or explosion**.
 - Never use charcoal that has been pre-treated with lighting fluid. **Use only a high grade plain charcoal or charcoal / wood mixture**.
 - **Do not use gasoline, kerosene or alcohol** for lighting charcoal. Use of any of these or similar products could cause an **explosion** possibly leading to severe bodily injury.
 - **Never** add charcoal lighting fluid to hot or even warm coals as flashback may occur causing severe burns.
 - **Place grill in an area where children and pets cannot come into contact with unit. Close supervision is necessary when grill is in use.**
 - **Do not leave grill unattended** when in use.
 - When adding charcoal and / or wood, use extreme caution and follow instructions in "Adding Charcoal / Wood During Cooking" section of this manual.
 - **Do not store or use grill** near gasoline or other flammable liquids, gases or where flammable vapors may be present.
 - **Do not store** lighter fluid or other flammable liquids or materials under the grill.
 - Use caution when adjusting cooking grate, **use oven mitt**. Handles will be hot when in use.
- Grill is hot when in use. To avoid burns:**
- DO NOT attempt to move the grill.
 - **Wear protective gloves or oven mitts.**
 - DO NOT touch any hot grill surfaces.
 - DO NOT wear loose clothing or allow hair to come in contact with grill.

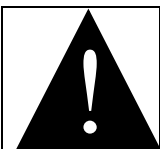

WARNING

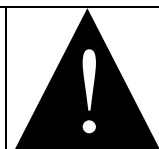

- When grilling, grease from meat may drip into the charcoal and cause a grease fire. **Do not use water to extinguish grease fires use a fire extinguisher.**
- **Use caution!** Keep hands, face and body a safe distance away.
- **Do not** allow charcoal and/or wood to rest on the walls of grill. Doing so will greatly reduce the life of the metal and finish of your grill.
- **Use caution** during assembly and while operating your grill to avoid scrapes or cuts from sharp edges of metal parts. **Use caution** when reaching into or under grill.
- In windy weather, place **grill** in an outdoor area that is **protected from the wind**.
- **Never leave** coals and ashes in grill **unattended**. Before grill can be left unattended, remaining coals and ashes must be removed from grill. **Use caution** to protect yourself and property. Carefully place remaining coals and ashes in a non-combustible metal container and saturate completely with water. Allow coals and water to remain in metal container 24 hours prior to disposing.
- **Extinguished coals and ashes** should be placed a **safe distance from** all structure and **combustible materials**.
- With a garden hose **completely wet** the surface beneath and around grill to extinguish any ashes, coals or embers which may have fallen during the cooking or cleaning process.
- After each use, **clean the grill thoroughly** and apply a light coat of vegetable oil to prevent rusting. **Do not** coat drain pipe with vegetable oil. **Cover the grill** to protect it from excessive rusting.
- **Use caution** when lifting or moving grill to prevent strains and back injuries.
- We advise that a **fire extinguisher** be on hand. Refer to your local authority to determine proper size and type of fire extinguisher.
- **Store** the grill **out of reach of children** and in a dry location when not in use.
- **Do not** attempt to service grill other than normal maintenance as explained in “After-Use Safety” and “Proper Care & Maintenance” sections of this manual.
- **Properly dispose** of all packaging material

Use caution and common sense when operating your grill.

Failure to adhere to safety warning and guidelines in this manual could result in bodily injury or property damage.

Save this manual for future reference.

Always wash your hands after handling this product

California Prop 65 Statement

 **WARNING:** This product can expose you to chemicals including soot, which is known to the State of California to cause cancer, and carbon monoxide, which is known to the State of California to cause birth defects or other reproductive harm. For more information go to www.P65Warnings.ca.gov.

ASSEMBLY INSTRUCTIONS

THANK YOU FOR PURCHASING THIS COWBOY FIREPIT & GRILL

Read all safety warnings & assembly instructions carefully before assembling or operating your grill.

For missing parts, please contact customer service at customerservice@rankam.com or at 888-837-1380 (U.S. only)

(Proof of purchase will be required.)

Inspect contents of the box to ensure all parts are included and undamaged.

We recommend two people for assembly of this firepit & grill.

The following **tools** are required for assembly and are not **included**:

- Pliers
- Philips & Flathead Screwdrivers
- Adjustable Wrench

Product Diagram

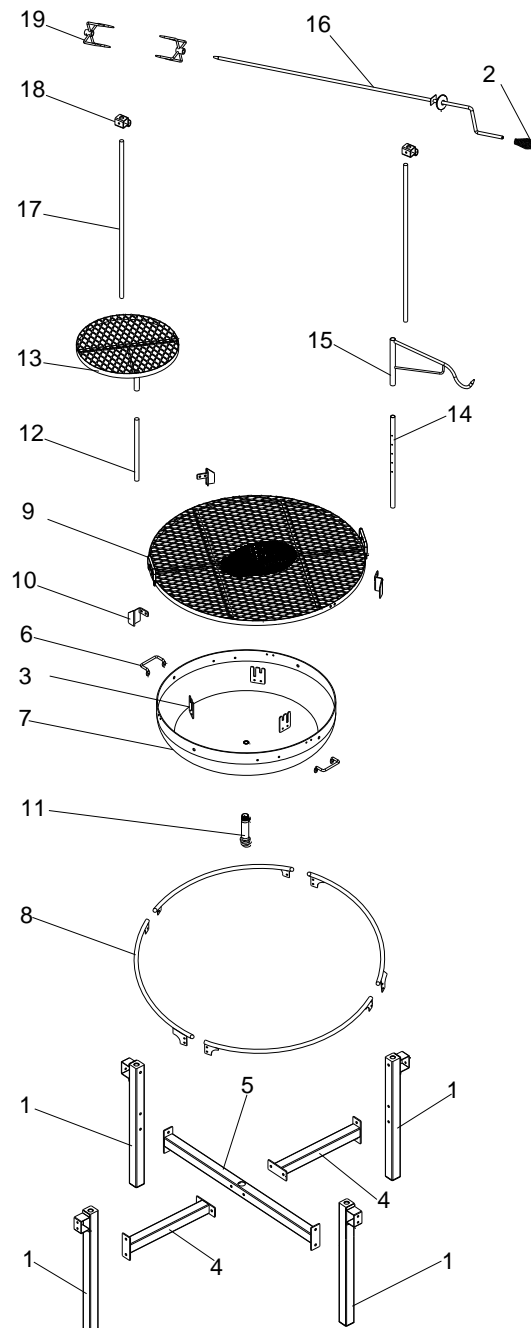



Replacement Parts List

STOP! DO NOT RETURN TO RETAILER.

For assembly assistance, missing or damaged parts, please call customer service 888-837-1380, or email customerservice@rankam.com

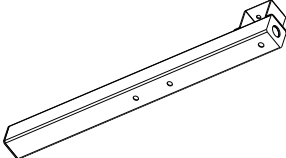
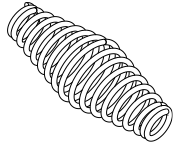
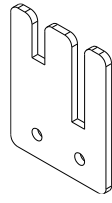
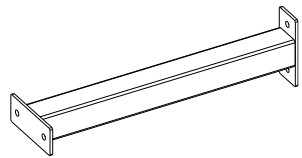
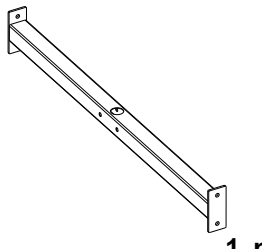
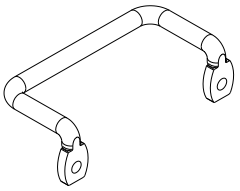
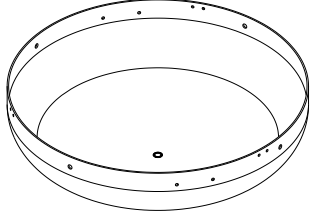

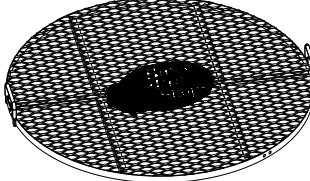
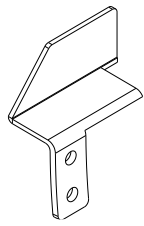
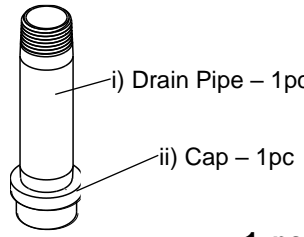
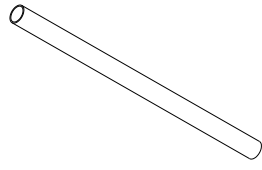
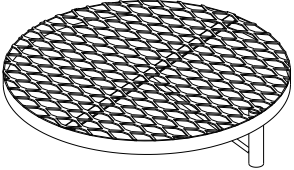
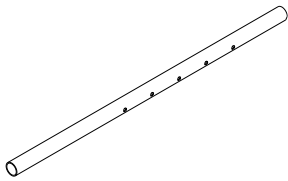
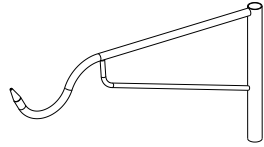
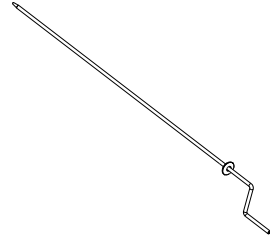
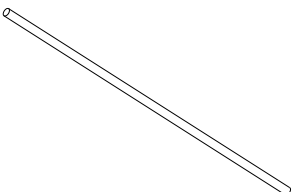
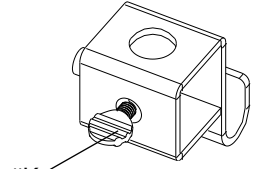
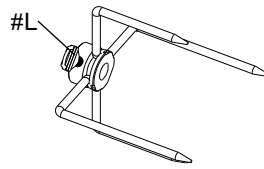









Component List

<p>1. Leg</p>  <p>4 pcs</p>	<p>2. Handle Coil</p>  <p>1 pc</p>	<p>3. Grate Support Plate</p>  <p>3 pcs</p>	<p>4. Short Horizontal Bar</p>  <p>2 pcs</p>
<p>5. Long Horizontal Bar</p>  <p>1 pc</p>	<p>6. Handle</p>  <p>2 pcs</p>	<p>7. Fire Bowl</p>  <p>1 pc</p>	<p>8. Guard Ring</p>  <p>4 pcs</p>
<p>9. Cooking Grate</p>  <p>1 pc</p>	<p>10. Grate Bracket</p>  <p>3 pcs</p>	<p>11. Drain Pipe</p>  <p>i) Drain Pipe – 1pc ii) Cap – 1pc</p> <p>1 pc</p>	<p>12. Short Column</p>  <p>1 pc</p>
<p>13. Work Table</p>  <p>1 pc</p>	<p>14. Height Adjustable Column</p>  <p>1 pc</p>	<p>15. Hanging Hook</p>  <p>1 pc</p>	<p>16. Rotisserie Rod</p>  <p>1 pc</p>
<p>17. Long Column</p>  <p>2 pcs</p>	<p>18. Rotisserie Holder</p>  <p>#K</p> <p>2 pcs</p>	<p>19. Rotisserie</p>  <p>#L</p> <p>2 pcs</p>	

Replacement Parts

Component	Name	Part Number
1	Leg	MET-CB0001
2	Handle Coil	MET-CB0002
3	Grate Support Plate	MET-CB0003
4	Short Horizontal Bar	MET-CB0004
5	Long Horizontal Bar	MET-CB0005
6	Handle	MET-CB0006
7	Fire Bowl	MET-CB0007
8	Guard Ring	MET-CB0008
9	Cooking Grate	MET-CB0009
10	Grate Bracket	MET-CB0010
11	Drain Pipe & Cap	MET-CB0011
12	Short Column	MET-CB0012
13	Work Table	MET-CB0013
14	Heigh Adjustable Column	MET-CB0014
15	Hanging Hook	MET-CB0015
16	Rotisserie Rod	MET-CB0016
17	Long Column	MET-CB0017
18	Rotisserie Holder & hardware K	MET-CB0018
19	Rotisserie & hardware L	MET-CB0019
20	Hardware Pack	HAR-CB0001

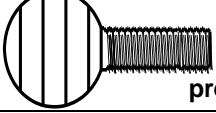
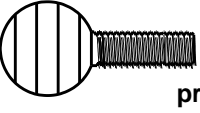
Hardware List

Item No.	Item name	Diagram	Qty
#A	Bolt M8x60		2 pcs
#B	Bolt M8x15		8 pcs
#C	Bolt M6x20		10 pcs
#D	Bolt M6x15		12 pcs
#E	Bolt M6x15		6 pcs
#F	Nut M8		2 pcs
#G	Nut M6		10 pcs
#H	Nut M6		6 pcs
#I	Hook Pin		1 pc
#J	Cotter Pin		1 pc
#K	Bolt M8x15	 pre-attached on components	2 pcs
#L	Bolt M6x15	 pre-attached on components	2 pcs
#M	Bolt M4x8		1 pc
#N	Flat Washer		1 pc

Symbol: The following symbols will be shown in each procedure for indication of tightening the bolt and nut if necessary.



Hand Tighten only at this time

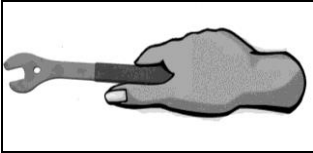

Tighten with tools at this time

Some steps may require the assistance of a friend.

Step 1

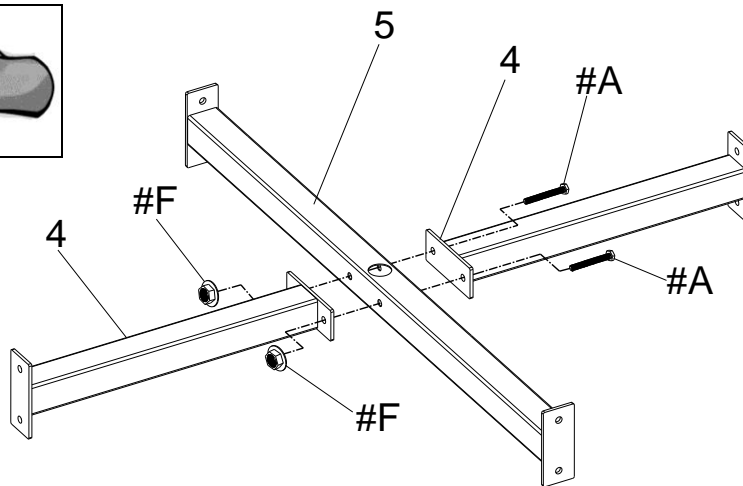
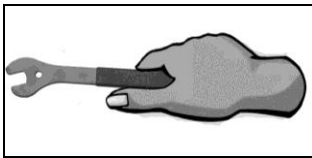

Step 2

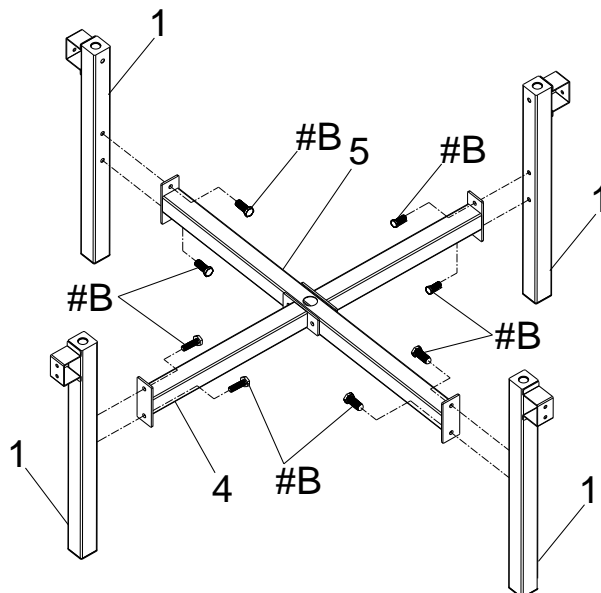
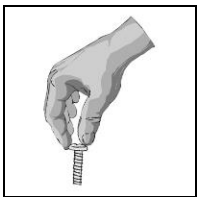

Step 3

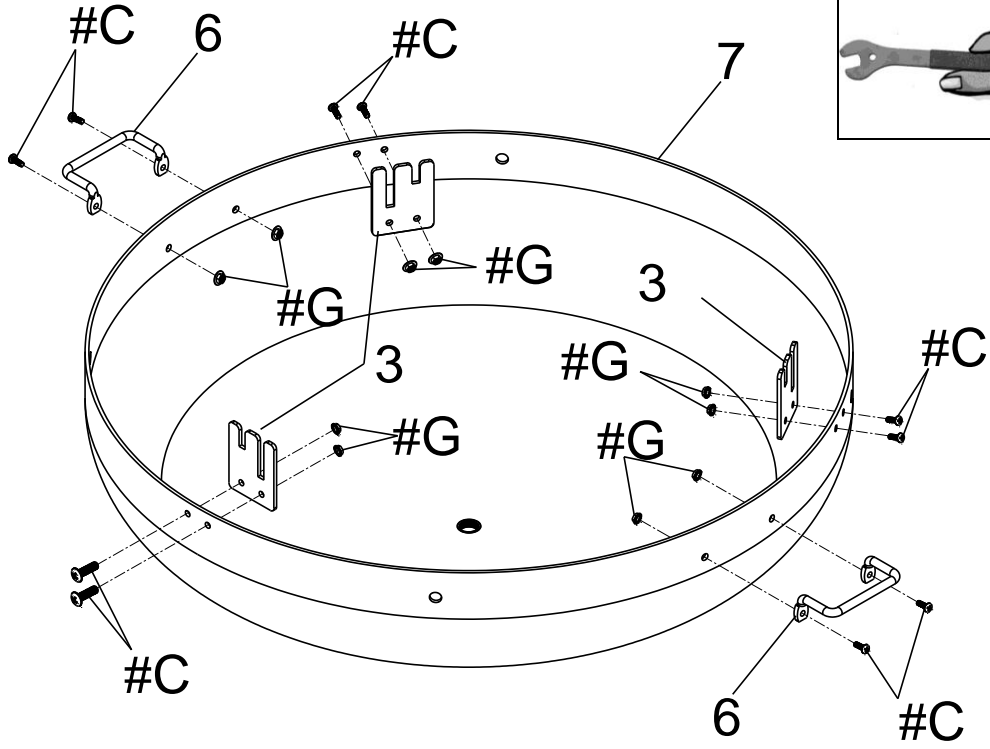

Step 4

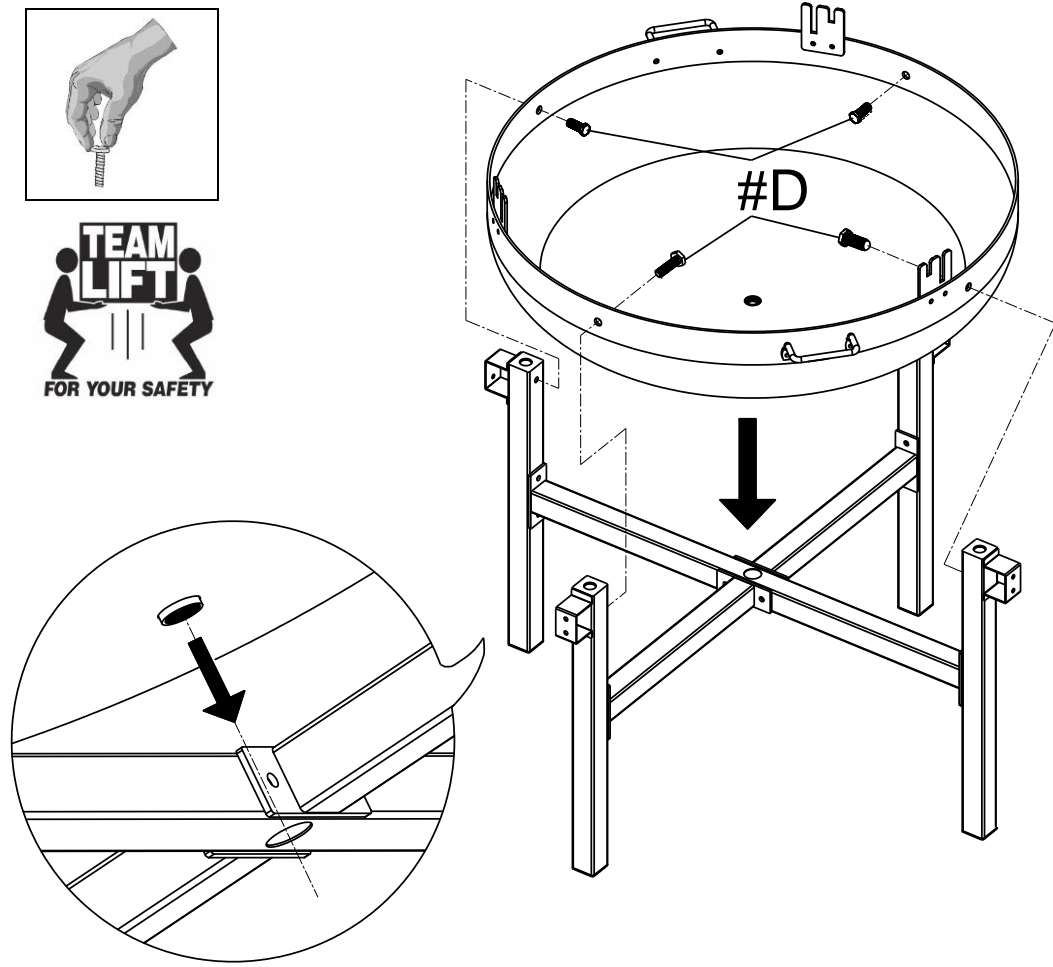

Step 5 – Tighten all bolts.

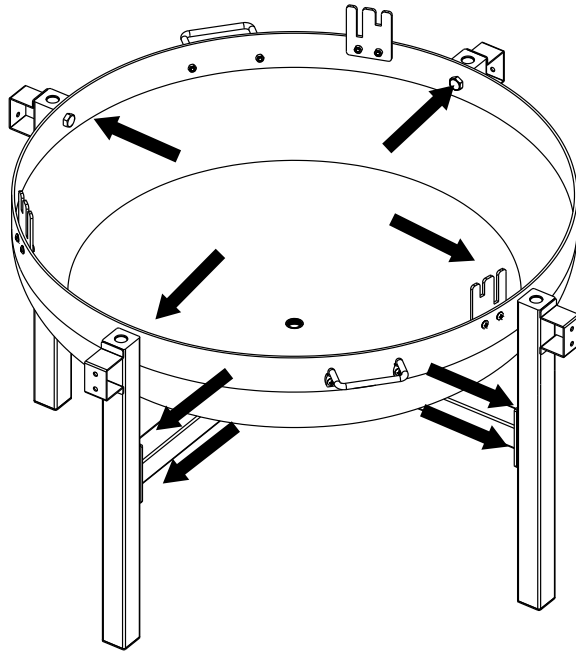
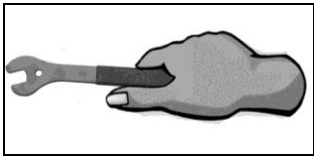

Step 6

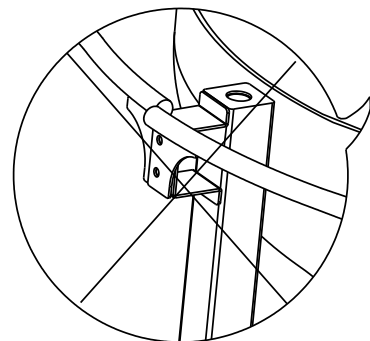
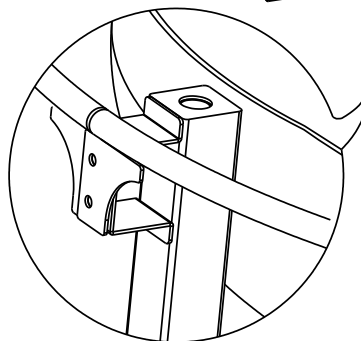
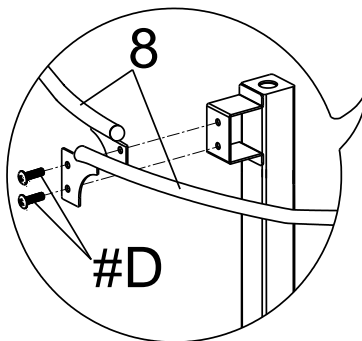
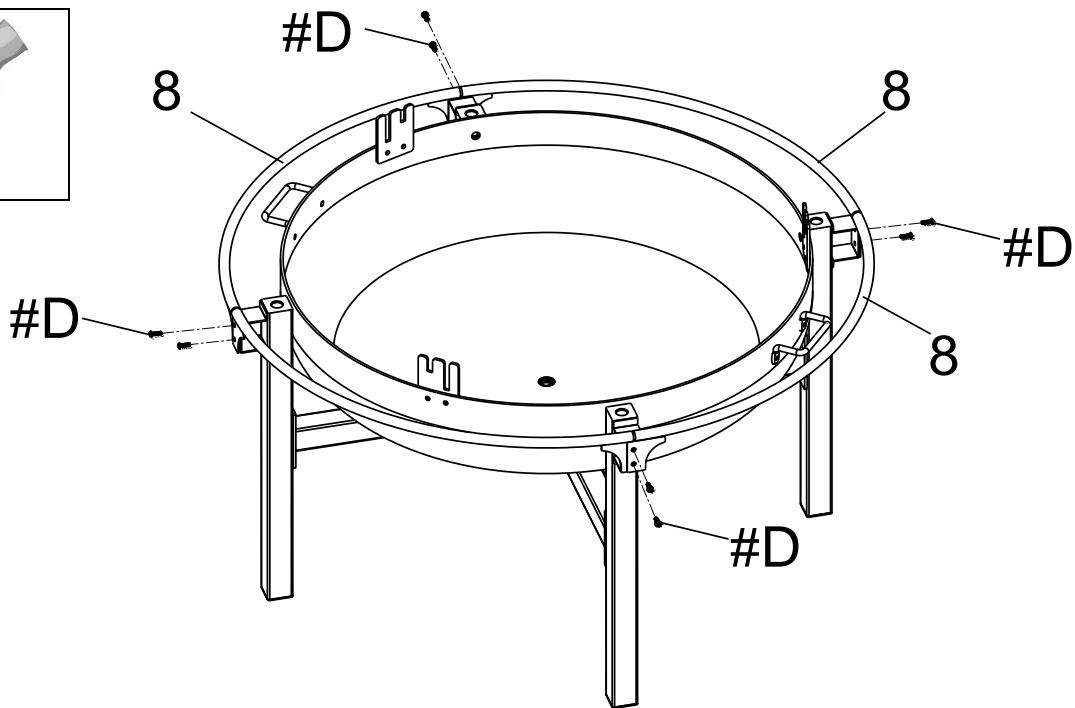
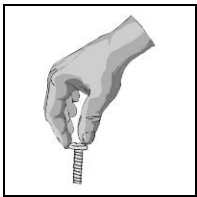

Step 7

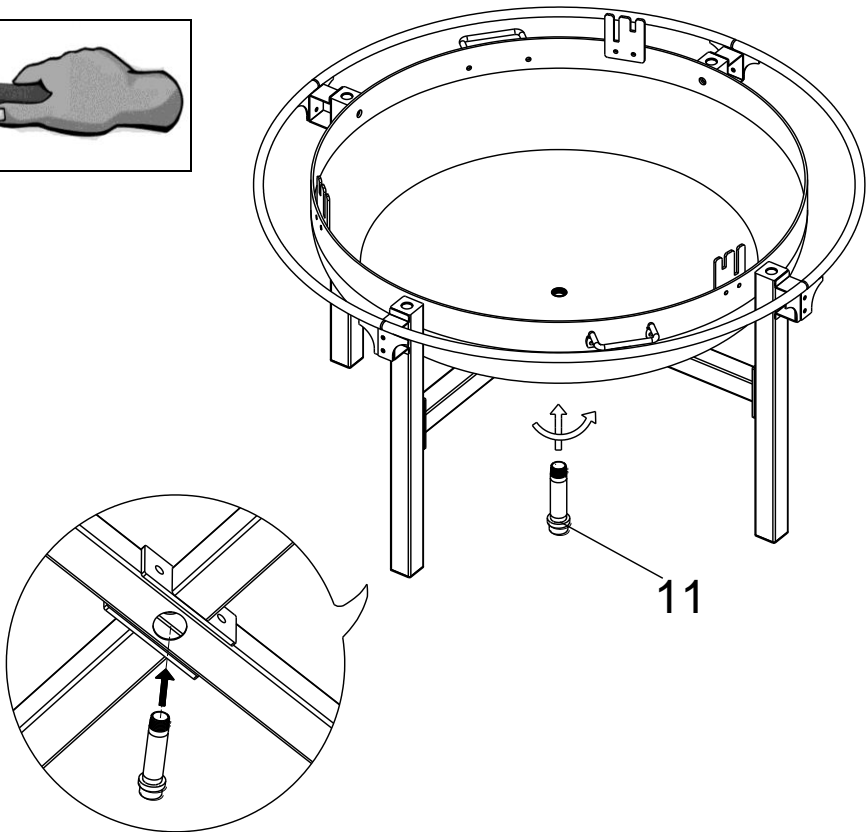
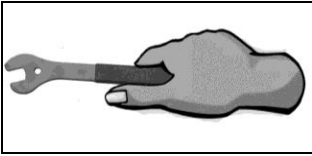

Step 8

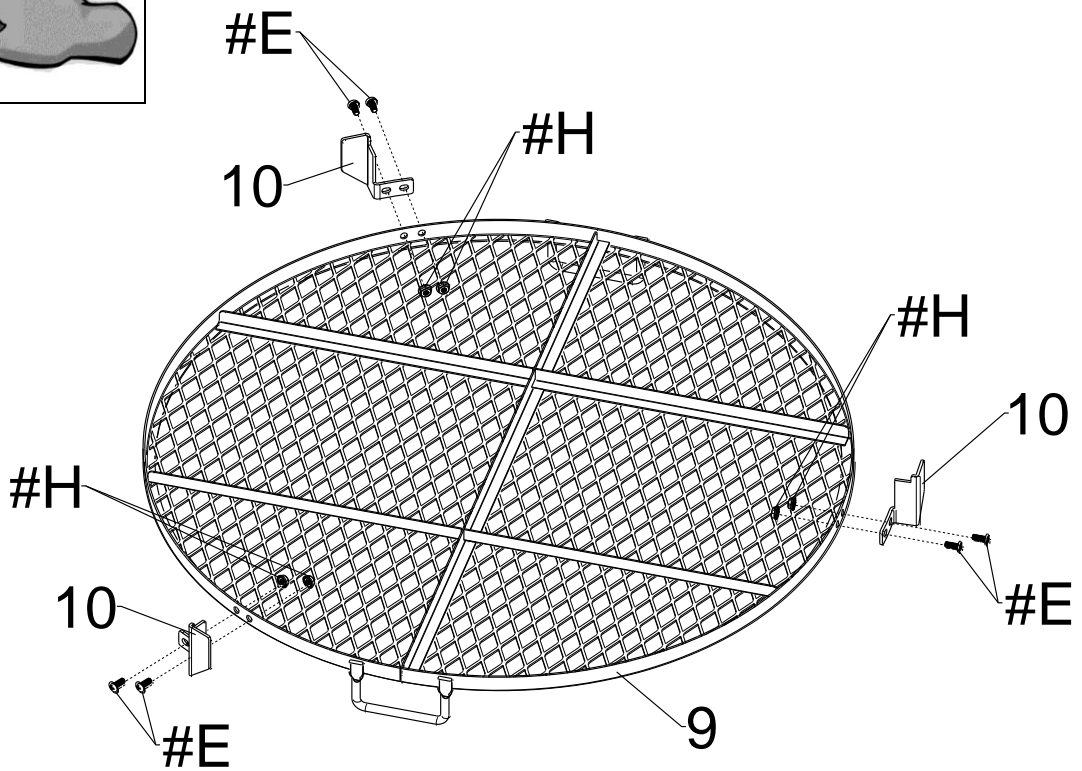
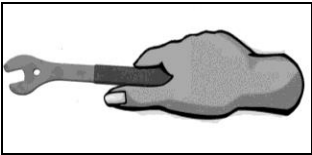

Step 9

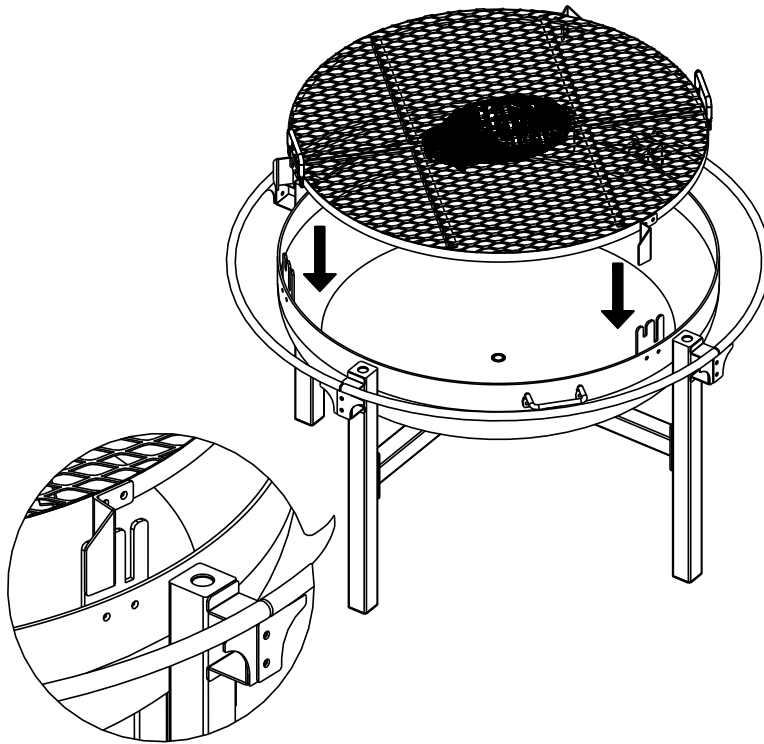

Step 10

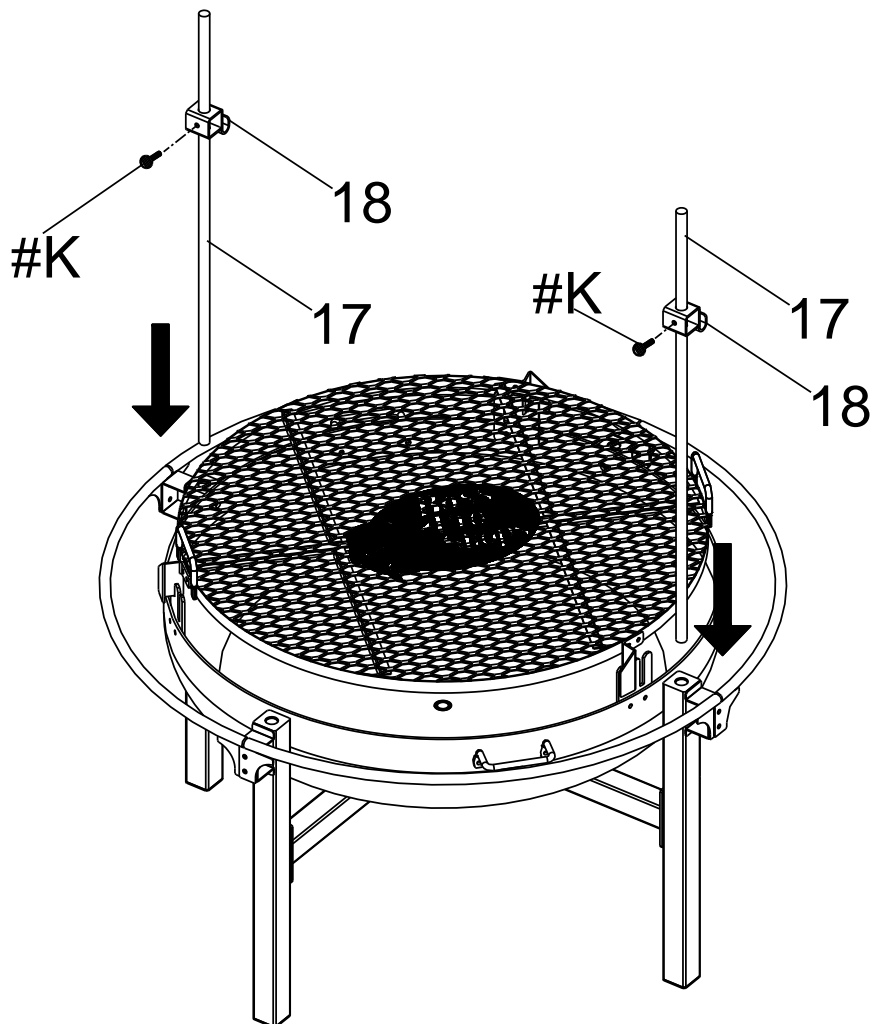
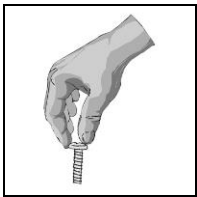

Step 11

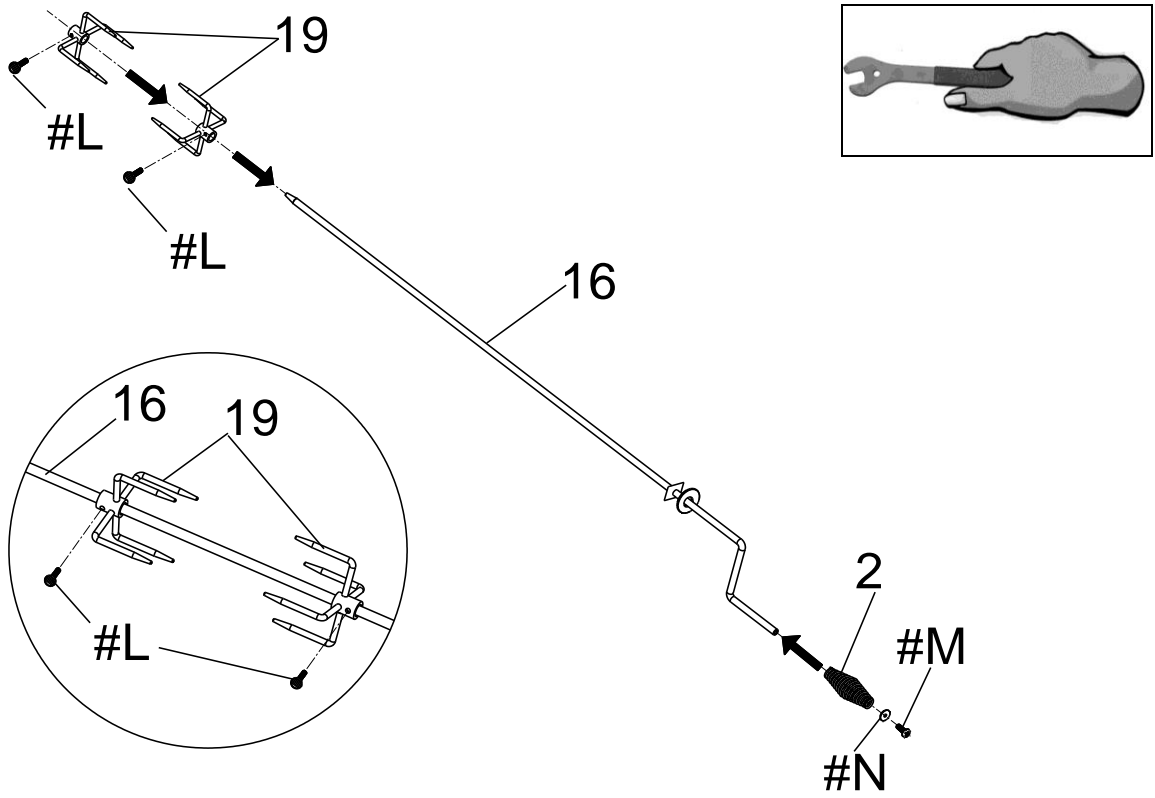

Step 12

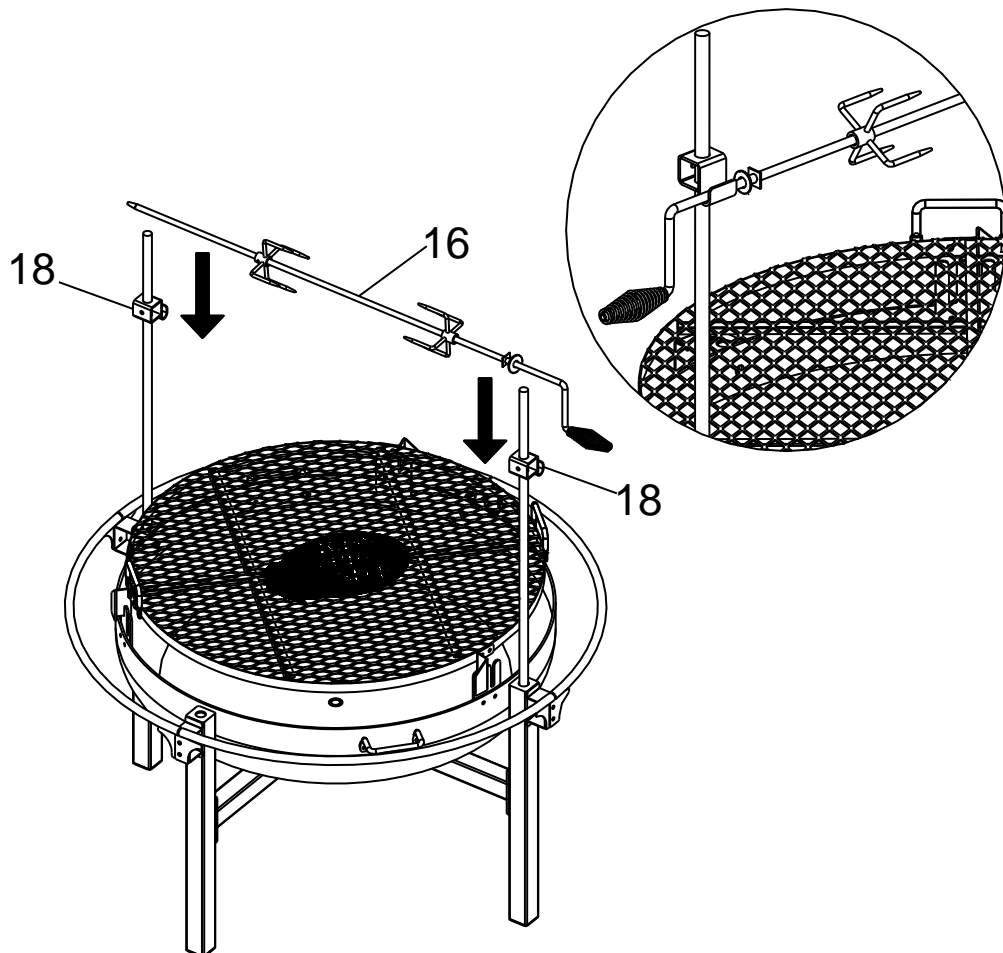

Step 13

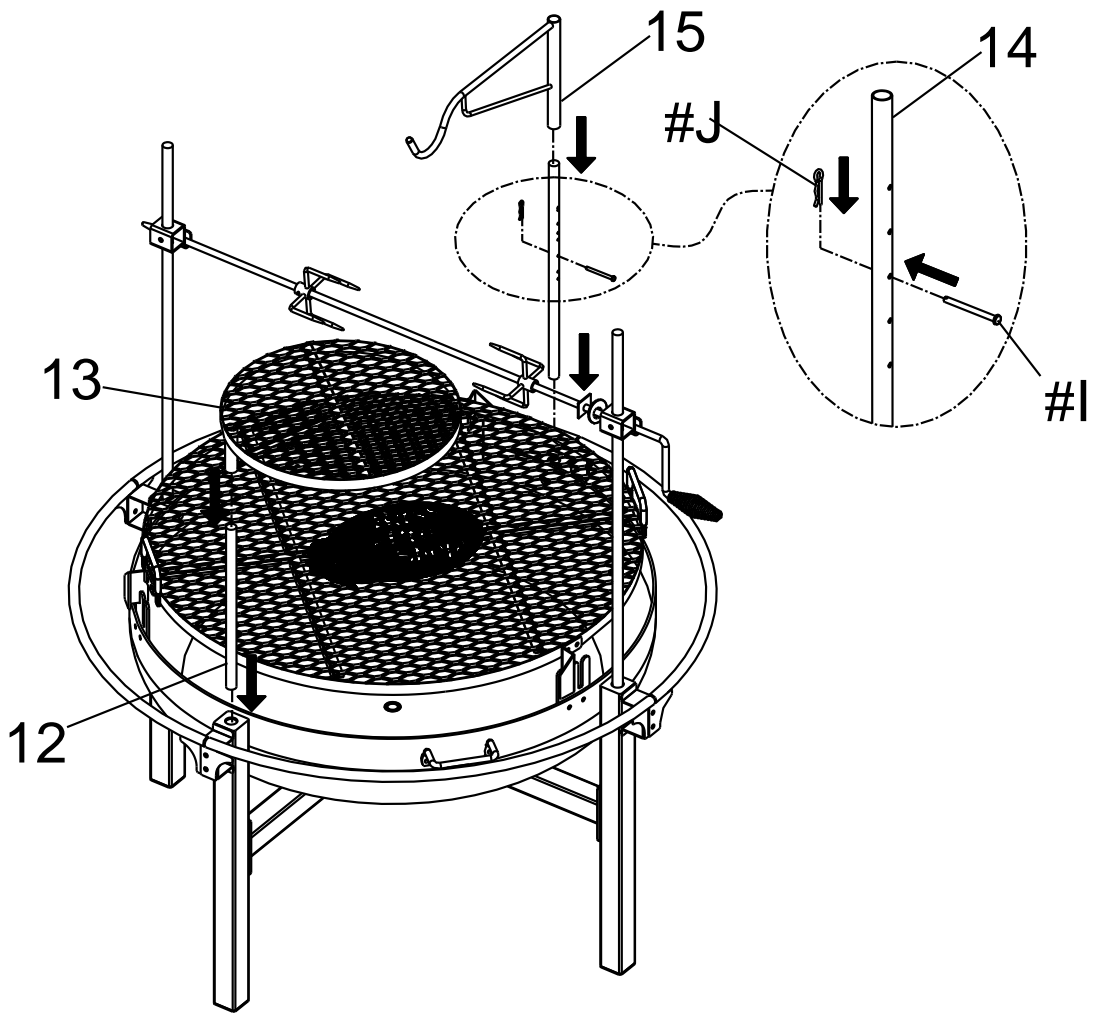

WARNING



DO NOT use grill when the drain pipe cap is removed. DO NOT attempt to remove the drain pipe cap while the grill is hot.



WARNING



Place the grill **outdoors** on a **hard, level, non-combustible surface** away from roof overhang or any combustible material. **Never use** on wooden or other surfaces that could burn. Place the grill away from open windows or doors to **prevent smoke** from entering your house. In windy weather, place the grill in an outdoor area that is protected from the wind.



WARNING



Read all safety warnings and instructions carefully before operating your grill.

PREPARATION FOR USE & LIGHTING INSTRUCTIONS

Curing your grill

Prior to your first use of the Grill, follow the instructions below carefully to cure your grill. Curing your grill will minimize damage to the exterior finish as well as rid the grill of paint odor that can impart unnatural flavors to the first meal prepared on the grill.

IMPORTANT: To protect your grill from excessive rust, the unit must be properly cured and covered at all times when not in use.

Step 1

Lightly coat all interior surfaces and cooking grate of the grill with vegetable oil or vegetable oil spray. **Do not** coat drain pipe.

Step 2

Follow the instructions below carefully to build a fire. You may use charcoal and/or wood as fuel in the grill (see “Adding Charcoal/Wood During Cooking” section of this manual).

NOTE: It is important that the exterior of the grill is not scraped or rubbed during the curing process.

IMPORTANT: to protect your grill from excessive rust, the unit must be cured periodically and covered at all times when not in use.

OPERATING INSTRUCTIONS

Step 1

Lightly coat all interior surfaces and cooking grate of the grill including cooking grills with vegetable oil or vegetable oil spray. Do not coat drain pipe.

Step 2

Follow the instructions below carefully to build a fire. You may use charcoal and/or wood as fuel in the grill.

	<h1>WARNING</h1>	
<p>Never use charcoal that has been pre-treated with lighter fluid. Use only a high grade plain charcoal or charcoal/wood mixture.</p>		

If using a Charcoal Chimney Starter, follow all manufacturer’s warnings and instructions regarding the use of their product, and start with 10 pounds (4.6 kg) of charcoal. When charcoal is burning strong, carefully place hot coals in center of the bowl.

	<h1>WARNING</h1>	
<p>DO NOT use grill when the drain pipe cap is removed. DO NOT attempt to remove the drain pipe cap while the grill is hot.</p>		

NOTE: to extend the life of your grill, make sure that hot coals and wood do not touch the straight wall of grill.

IF USING CHARCOAL CHIMNEY STARTER, PROCEED TO STEP 5.

If you choose to use charcoal lighting fluid, **ONLY use charcoal lighting fluid** approved for lighting charcoal. **Do not use gasoline, kerosene, alcohol** or other flammable materials for lighting charcoal. Follow all manufacturer’s warnings and instructions regarding the use of their product. Start with 10 pounds (4.6 kg) of charcoal. Place the charcoal in center of the grill.

Step 3

Saturate charcoal with lighting fluid. Wait 2 to 3 minutes to allow lighting fluid to soak into charcoal. **Store charcoal lighting fluid a safe distance from the grill.**

Step 4

Stand back and carefully light charcoal and allow to burn until covered with a light ash (approximately 20 minutes).

	<h1>WARNING</h1>	
Charcoal lighting fluid must be allowed to completely burn off (approximately 20 minutes). Failure to do this could trap fumes from charcoal lighting fluid in grill and may result in a flash-fire or explosion .		

Step 5

Always wear oven mitts/gloves when placing cooking grate on grill.

	<h1>WARNING</h1>	
Always wear oven mitts/gloves when adjusting cooking levels, or moving cooking grate to protect your hands from burns.		

Step 6

Place food on cooking grate. **Always use a meat thermometer** to ensure food is fully cooked before removing from grill.

Step 7

Allow grill to cool completely and then follow instructions in the “After-Use Safety” and “Proper Care & Maintenance” sections of this manual.

Regulating Heat

To increase heat, more wood and/or charcoal may be needed. Follow instructions in “Adding Charcoal/Wood During Cooking” section of this manual.

To maintain the temperature, more wood and/or charcoal may need to be added during the cooking cycle.

NOTE: Dry wood burns hotter than charcoal, so you may want to increase the ratio of wood to charcoal to increase the cooking temperature. Hardwood such as oak, hickory, mesquite, fruit and nut wood are an excellent fuel because of their burning rate. When using wood as fuel, make sure the wood is seasoned and dry. **DO NOT use** resinous wood such as **pine** as it will produce an unpleasant taste.

Adding Charcoal/Wood During Cooking

Additional charcoal and/or wood may be required to maintain or increase cooking temperature.

Step 1

Stand back. Use caution since **flames can flare-up**.

Step 2

Wearing oven mitts/gloves, adjust the cooking grate to protect your hands from burns.

Step 3

Stand back a safe distance and **use long cooking tongs** to lightly brush aside ashes on hot coals. Use cooking tongs to add charcoal and/or wood to the bowl of the grill, being careful not to stir-up ashes and sparks. If necessary, use your Charcoal Chimney Starter to light additional charcoal and/or wood and add to existing fire.



Step 4

When charcoal is burning strong again, **wear oven mitts/gloves** and carefully return cooking grate to grill body. Extinguish any hot ashes, coals or embers which may have fallen from the grill or beneath and around grill.

AFTER-USE SAFETY



- **Always** allow grill and all components to **cool completely** before handling.
- **Never leave** coals and ashes in grill **unattended**. Make sure coals and ashes are **completely extinguished before removing**.
- **Before grill can be left unattended**, remaining coals and ashes must be removed from grill. Use caution to protect yourself and property. Place remaining coals and ashes in a non-combustible metal container and completely **saturate with water**. Allow coals and water to remain in metal container 24 hours prior to disposing.
- Extinguished **coals and ashes** should be placed a **safe distance from all structures and combustible materials**.
- With a garden hose, **completely wet surface beneath and around the grill** to extinguish any ashes, coals or embers which may have fallen during the cooking or cleaning process.
- **Cover and store** grill in a protected area **away from children and pets**.

Proper Care & Maintenance

- Cure your grill periodically throughout the year to protect against excessive rust.
- To protect your grill from excessive rust, the unit must be properly cured and covered at all times when not in use.
- Wash cooking grill and charcoal grates (when available) with hot, soapy water, rinse well and dry. Lightly coat grill and cooking grate with vegetable oil or vegetable oil spray, but **do not** coat drain pipe.
- Clean inside and outside of grill by wiping off with a damp cloth. Apply a light coat of vegetable oil or vegetable oil spray to the interior surface and cooking grate to prevent rusting. Do not coat drain pipe.
- If rust appears on the exterior surface of your grill, clean and buff the affected area with steel wool or fine grit emery cloth. Touch-up with a good quality high-temperature resistant paint.
- Never apply paint to the interior surface. Rust spots on the interior surface can be buffed, cleaned, and then lightly coated with vegetable oil or vegetable oil spray to minimize rusting.

LIMITED WARRANTY

1. Manufacturer warrants this Product to be free from defects in workmanship and materials for a period of Ninety (90) days from the date of purchase, PROVIDED claims are submitted, in writing, with proof of purchase.
2. If any part of this item fails because of a manufacturing defect within the Limited Warranty Period, Manufacturer offers to replace such part(s) provide that such parts have not been improperly repaired, altered, or tampered with or subject to misuse, abuse or exposed to corrosive conditions. This Limited Warranty is, however, subject to certain limitations, exclusions, time limits and exceptions (Hereinafter "Conditions") as listed below. Read these Conditions carefully.
3. This Limited Warranty shall be limited to the replacement or repair of any part(s) which Manufacturer determines, after reasonable examination, to have been defective at the time of manufacturing and manufacturer's obligation(s) shall be limited to replacement, if any, of defective part(s) which shall be shipped at Original Purchaser's expense to Original Purchaser's designated shipping address.
4. This Limited Warranty is given to and covers the **ORIGINAL PURCHASER ONLY** and such coverage terminates Ninety (90) days from the date of purchase.
5. **DAMAGE LIMITATION WARNING:** IN NO EVENT SHALL MANUFACTURER BE LIABLE FOR ANY INCIDENTAL OR CONSEQUENTIAL DAMAGES, INCLUDING (BUT NOT LIMITED TO) LOSS OF USE OF THE PRODUCT, LOSS OF TIME, INCONVENIENCE, EXPENSES FOR TRAVEL, TRANSPORTATION LODGING EXPENSES, LOSS OF FOOD, LOSS BY DAMAGE TO PERSONAL PROPERTY OR LOSS OF INCOME, PROFITS OR REVENUE.
6. **MANUFACTURER'S OBLIGATION:** Manufacturer's liability shall be limited to the delivery of a good, merchantable Product and, if necessary, the repair or replacement, at manufacturer's option, of any defective part or unit.
7. **TRANSFER LIMITATIONS:** This Limited Warranty is not assignable or transferable. It covers only the original purchaser.
8. **RESERVED RIGHT TO CHANGE:** Manufacturer reserves the right to make changes or improvements to products it produces in the future without imposing on itself any obligations to install the same improvements in the products it has previously manufactured.
9. This Limited Warranty gives the Original Purchaser specific legal rights but there may be other rights which vary by jurisdiction.
10. This warranty does not cover the following items:
 - Chips or scratches on porcelain or painted surfaces
 - Rust or corrosion is not deemed a manufacturing or materials defect
 - Discoloration or loss of paint due to handling during assembly, heat or cleaning products. Paint may require touch up.
 - Stainless steel discoloration or corrosion
 - Consumables such as batteries

IF CUSTOMER SERVICE BECOME NECESSARY:

1. The Original Purchaser is responsible for shipping and handling charges of the returned item(s) and replacement parts, if any.
2. All parts to be replaced will need to be shipped before replacement items will be sent.
3. Follow the Customer Service Representative's instructions exactly. If a return is necessary, it must be packed carefully and shipped prepaid.

Should you encounter any problem
or
Obtaining replacement parts

CALL US FIRST.

Do not return product to the store.

WE CAN HELP.

Rankam (China) Manufacturing Co. Ltd.

18/F., New Lee Wah Centre, 88 Tokwawan Road, Kowloon, Hong Kong

Please contact Rankam Customer Service at customerservice@rankam.com
or at 1-888-837-1380, Mon to Fri, 8:00 a.m. – 5:00 p.m. Pacific Standard Time.

Made in China