

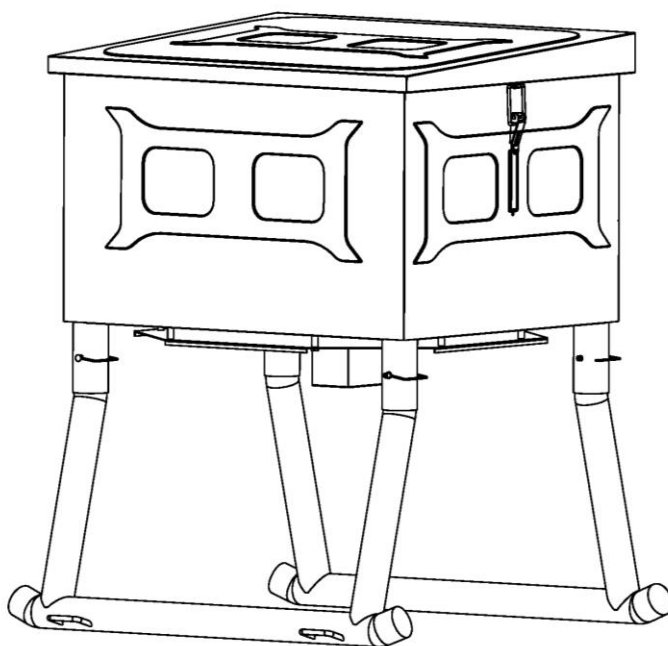

GAME WINNER®

Assembly Instructions

**320lb No-Hassle Feeder
Model # 161716 (HU2327701-GW)**



Please keep this instruction manual for future reference

**Customer Service: 1-888-837-1380, 8:00am to 5:00pm, Pacific Standard Time,
Monday thru Friday**

Email: customerservice@rankam.com

----- OR -----

Customer Service: 1-888-922-2336, 7:00am to 12:00am CST daily

Live Chat at: www.academy.com

Email: customerservice@academy.com

(Made in China)

Warnings ----- **3-6**
Parts List ----- **7**
Hardware List ----- **7**
Product Diagram ----- **8**
Assembly Instructions ----- **9-10**
Operating Instructions ----- **11**
Connecting Battery ----- **11**
Using Solar Panel ----- **11**
How To Load Your Feeder----- **12**
Care and Maintenance ----- **12**
Replacement Parts----- **13-14**
Warranty ----- **15-16**

NOTE: Before beginning assembly of product, make sure all parts are present. Compare parts with package content list and hardware contents. If any part is missing or damaged, do not attempt to assemble the unit. Contact customer service for replacement parts.

Warnings

PAY ATTENTION to these statements when reading this manual as the information contained can save your life.

⚠ DANGER: Indicates an imminently hazardous situation which, if not avoided, will result in death or serious injury.

⚠ WARNING: Be alert to the possibility of serious bodily injury if the instructions are not followed. Be sure to read and carefully follow all of the messages.

⚠ CAUTION: Indicates a potentially hazardous situation which, if not avoided, may result in minor or moderate injury.

YOUR **GAME WINNER 320LB NO-HASSLE FEEDER** IS DESIGNED, ENGINEERED AND CONSTRUCTED IN A MANNER THAT MAKES IT A RUGGED PIECE OF HUNTING EQUIPMENT THAT WILL GIVE YOU YEARS OF SERVICE. THIS RUGGED CONSTRUCTION MAKES YOUR FEEDER PHYSICALLY HEAVY. AS SUCH, YOU SHOULD NEVER ATTEMPT TO ASSEMBLE THIS FEEDER ALONE. YOU MUST HAVE A MINIMUM OF TWO (2) ADULTS FOR THE SAFE ERECTION OF YOUR FEEDER. FAILURE TO FOLLOW THESE INSTRUCTIONS MAY RESULT IN SERIOUS INJURY OR DEATH!

THIS FEEDER MUST BE ERECTED ONLY ON A FIRM AND LEVEL GROUND. BEFORE FILLING THE HOPPER, **RECOMMEND INSTALLING FOUR (4) STAKES (NOT INCLUDED)**. FAILURE TO FOLLOW THESE INSTRUCTIONS MAY RESULT IN SERIOUS INJURY OR DEATH!

REFER TO THE IMAGES IN THIS MANUAL FOR VISUALIZATION OF THE ASSEMBLY PROCESS IN ADDITION TO READING THE INSTRUCTIONS.

SOME PARTS MAY CONTAIN SHARP EDGES, SHARP POINTS, OR EDGES THAT CAN SCRATCH, POKE, OR PUNCTURE. WEAR APPROPRIATE CLOTHING AND SAFETY GLOVES DURING ASSEMBLY.

PRIOR TO ATTEMPTING TO USE THIS UNIT, TAKE A MOMENT TO BECOME FAMILIAR WITH THE ASSEMBLY, SETUP, AND INSTALLATION. FAILURE TO FOLLOW THESE INSTRUCTIONS MAY RESULT IN SERIOUS INJURY OR DEATH!

Warnings

DO NOT USE THIS UNIT AROUND POWER GENERATING EQUIPMENT (TRANSFORMERS, GENERATORS, SUBSTATIONS, ETC) AND/OR TRANSMISSION EQUIPMENT (POWER LINES). FAILURE TO FOLLOW THESE INSTRUCTIONS MAY RESULT IN SERIOUS INJURY OR DEATH!

DO NOT LOAD FEEDER WITHOUT ANOTHER ADULT. FAILURE TO FOLLOW THESE INSTRUCTIONS MAY RESULT IN SERIOUS INJURY OR DEATH!

DO NOT LOAD FEEDER UNDER AND/OR DURING BAD WEATHER SUCH AS STORMS, SNOW, LIGHTNING, OR THUNDERSTORMS. FAILURE TO FOLLOW THESE INSTRUCTIONS MAY RESULTS IN SERIOUS INJURY OR DEATH!

DO NOT SIT OR STAND ON OR INSIDE THE HOPPER. FAILURE TO FOLLOW THESE INSTRUCTIONS MAY RESULT IN SERIOUS INJURY OR DEATH!

DO NOT LOAD OVER 320 POUNDS OF FEED. FAILURE TO FOLLOW THESE INSTRUCTIONS MAY RESULT IN SERIOUS DAMAGE TO THIS UNIT.

DO NOT LOAD FEEDER UNTIL IT IS COMPLETELY ASSEMBLED AND STANDING UP IN PLACE.

DO NOT STORE OR HANG ITEMS ON THE HOPPER. FAILURE TO FOLLOW THESE INSTRUCTIONS MAY RESULT IN SERIOUS DAMAGE TO THIS UNIT.

DO NOT DISASSEMBLE AND/OR REMOVE PARTS WITHOUT ANOTHER ADULT PRESENT. FAILURE TO FOLLOW THESE INSTRUCTIONS MAY RESULT IN SERIOUS INJURY OR DEATH!

DO NOT ASSEMBLE, DISASSEMBLE, AND/OR REMOVE PARTS FROM THE FEEDER UNDER AND/OR DURING BAD WEATHER SUCH AS STORMS, SNOW, LIGHTNING, OR THUNDERSTORMS. FAILURE TO FOLLOW THESE INSTRUCTIONS MAY RESULT IN SERIOUS INJURY OR DEATH!

THE 12V RECHARGEABLE BATTERY (NOT INCLUDED) SHOULD HAVE A COMPLETE CHARGE PRIOR TO THE FIRST TIME OF OPERATION. REFER TO THE USER INSTRUCTIONS PROVIDED WITH THE BATTERY.

Warnings

TO TEST YOUR FEEDER, FOLLOW THE INSTRUCTIONS IN THE TIMER MANUAL. DO NOT TEST FEEDER WHEN IT CONTAINS FEED. TEST FEEDER WHEN EMPTY ONLY! TESTING THE FEEDER WHILE IT CONTAINS FEED WILL CAUSE FEED TO BE DISCHARGED AT A HIGH VELOCITY AND COULD RESULT IN BODY INJURY. FAILURE TO FOLLOW THESE INSTRUCTIONS MAY RESULT IN SERIOUS INJURY OR DEATH!

THOROUGHLY INSPECT THE FEEDER PRIOR TO EACH USE FOR SIGNS OF WEAR, ROT, CORROSION, CRACKS, DETERIORATION, AND/OR ANY OTHER TYPE OF DEFECT. DO NOT USE THIS FEEDER IF IT SHOWS EVIDENCE OF WEAR, ROT, CORROSION, CRACKS, DETERIORATION, AND/OR ANY OTHER TYPE OF DEFECT. FAILURE TO FOLLOW THESE INSTRUCTIONS MAY RESULT IN SERIOUS INJURY OR DEATH. DO NOT REMOVE, MODIFY, AND/OR OMIT ANY PART OR OTHERWISE MECHANICALLY MODIFY THIS UNIT OR ITS ASSEMBLY IN ANY MANNER. MODIFICATION, OMISSION, AND/OR PART SUBSTITUTION MAY RESULT IN SERIOUS INJURY OR DEATH!

OPERATION IS SUBJECT TO THE FOLLOWING TWO CONDITIONS:

- THIS DEVICE MAY NOT CAUSE HARMFUL INTERFERENCE.
- THE DEVICE MUST ACCEPT ANY INTERFERENCE RECEIVED, INCLUDING INTERFERENCE THAT MAY CAUSE UNDESIRE OPERATION.

BEFORE STANDING UP THE FEEDER, YOU MUST...

- **CHECK ALL HARDWARE TO BE SURE IT IS IN PLACE AND TIGHT**
- **CHECK ALL BOLTS AND NUTS TO BE SURE THEY ARE FIRM AND TIGHT**
- **DO NOT THROW AWAY THE PACKAGING MATERIAL AT THIS TIME**

Warnings



! IMPORTANT !

THE MANUFACTURER OF THE 320LB NO-HASSLE FEEDER IS NOT RESPONSIBLE FOR ANY INACCURATE INFORMATION YOU HAVE RECEIVED REGARDING STATE FEEDING REGULATIONS. PLEASE ALWAYS KEEP YOUR INFORMATION UP-TO-DATE AND RELIABLE. MANY STATE LAWS CHANGE AND ARE AMENDED WITHOUT NOTICE. ALWAYS DOUBLE CHECK YOUR STATE AND SPECIFIC COUNTY FEEDING LAWS REGARDING THE USE OF FEEDERS.

Parts List

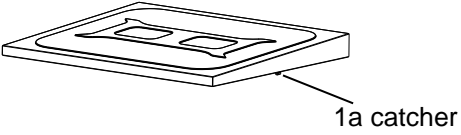
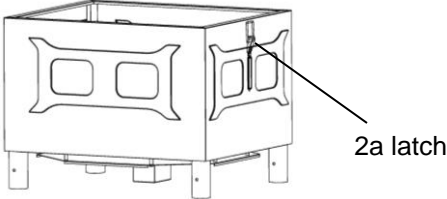
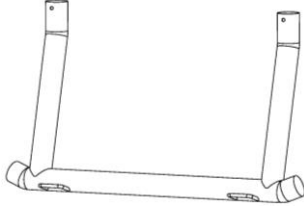
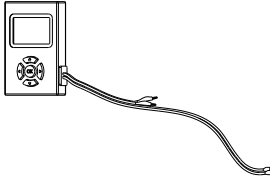
1	<p>Lid</p> <p>1a - catcher - 2 pcs (pre-attached on lid)</p>		1 pc
2	<p>Hopper</p> <p>2a - latch - 2 pcs (pre-attached on hopper)</p>		1 pc
3	Leg		2 pcs
4	Digital Timer		1 pc

Hardware List

A	Lock Pin		4 pcs
---	----------	--	-------

Product Diagram

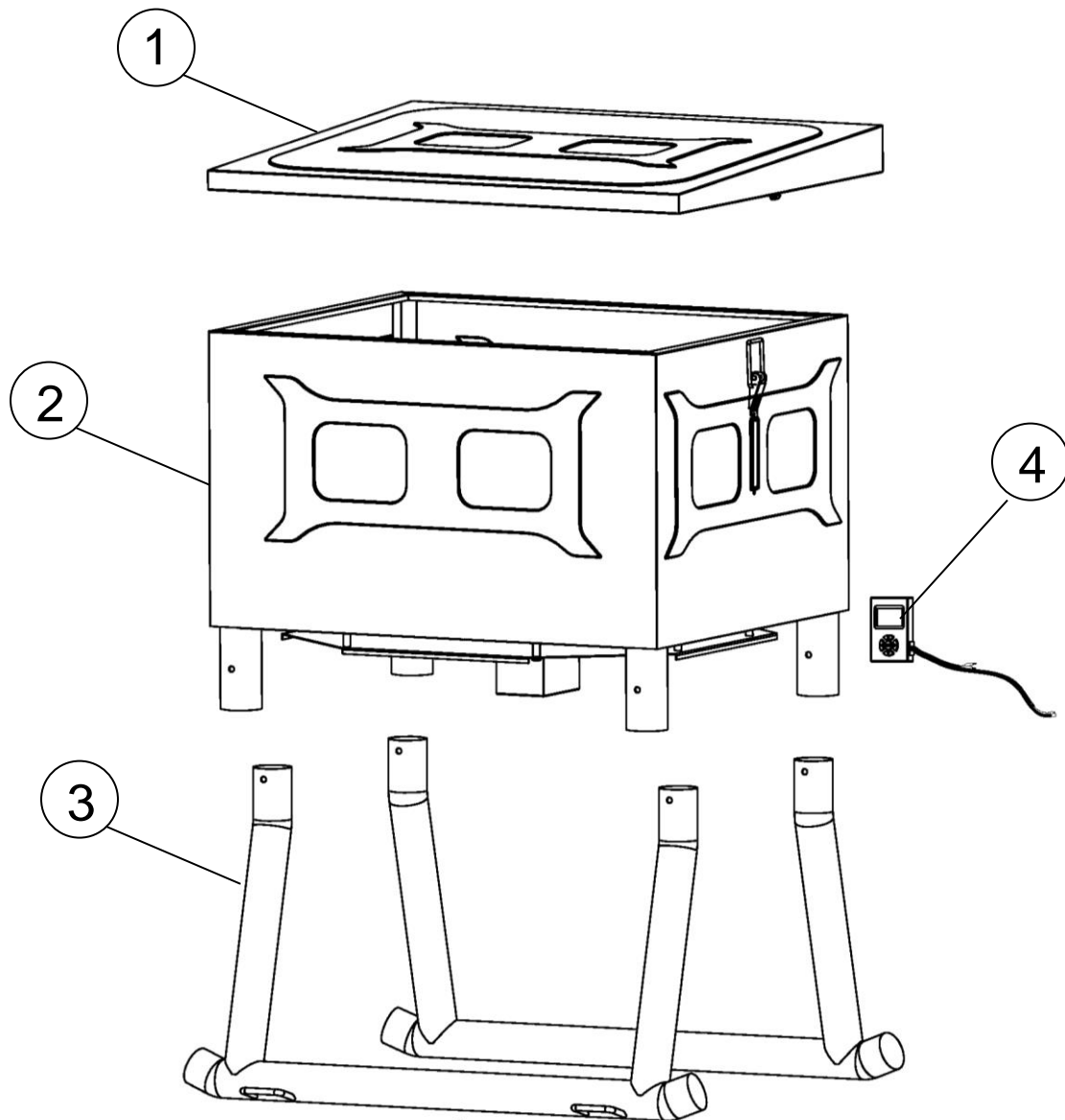

Assembly Instructions

Step 1:

Put Body Hopper (#2) upside down and insert legs (#3). Align holes on legs and attach Lock Pin (A)

Hardware :

#A - 4 pcs

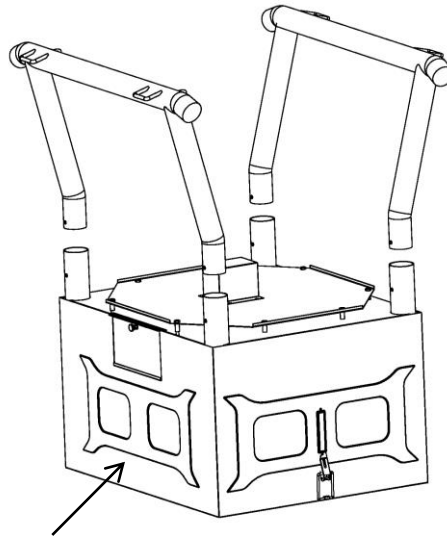

long side of hopper

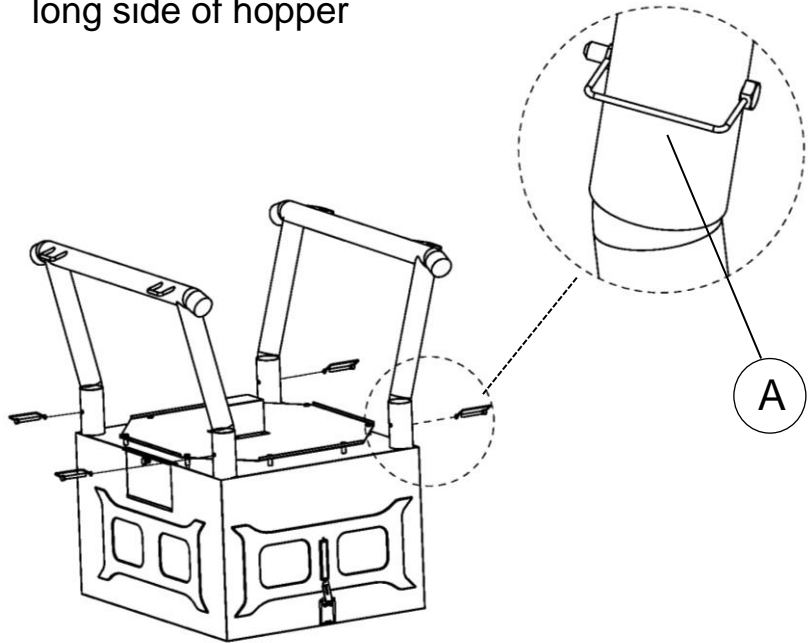

Using 2 adults, stand feeder upright on the pipe legs

⚠ WARNING: Feeder is heavy!

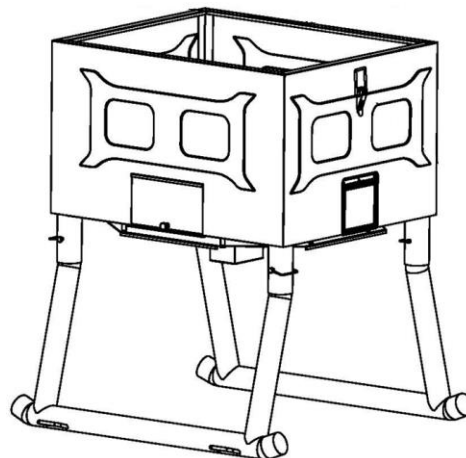

Assembly Instructions

Step 2:

Secure Lid (#1) with latches to hopper

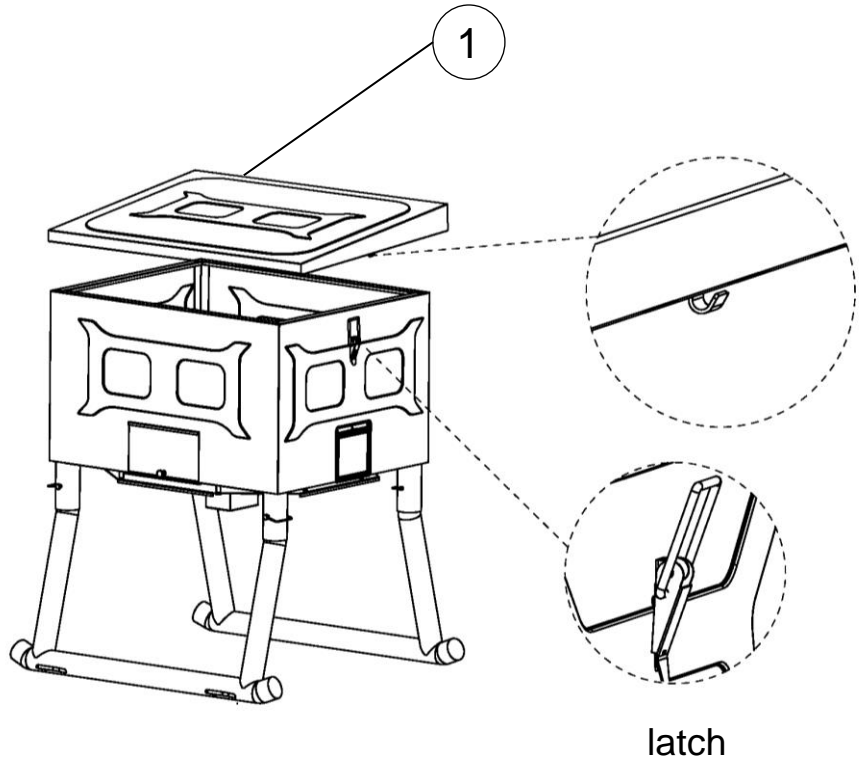

Your feeder assembly is completed.

Step 3:

Secure feeder to ground with Stakes (not included) through loops on legs

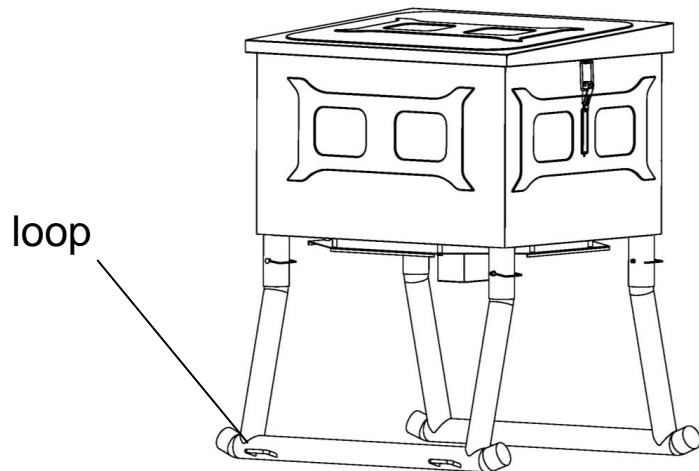

Operating Instructions

Connecting Battery

Install a 12V rechargeable battery (not included) by attaching Red alligator clip to the POSITIVE (+) terminal and Black alligator clip to the NEGATIVE (-) terminal.

****Avoid contact between exposed Red Positive (+) wire and exposed Black Negative (-) wire to prevent a short circuit in the digital timer. Always use insulating sleeves for all contacts.**

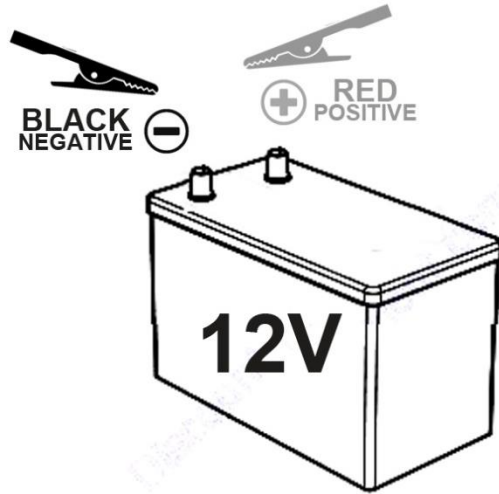

HOW TO OPERATE THE TIMER

READ THE OPERATION MANUAL INCLUDED IN THE PACKAGE.

Using Solar Panel

Connect the solar panel to the battery by attaching the red clip to the positive (+) terminal of the battery and the blue clip to the negative(-) terminal of the battery.

WARNING: DO NOT attach the red clip to the negative (-) terminal or the blue clip to the positive (+) terminal.

Loosen the bolt (pre-attached on hopper) to set position of solar panel.

Note: Leave Solar Panel closed if worried about cattle or other animals damaging it.

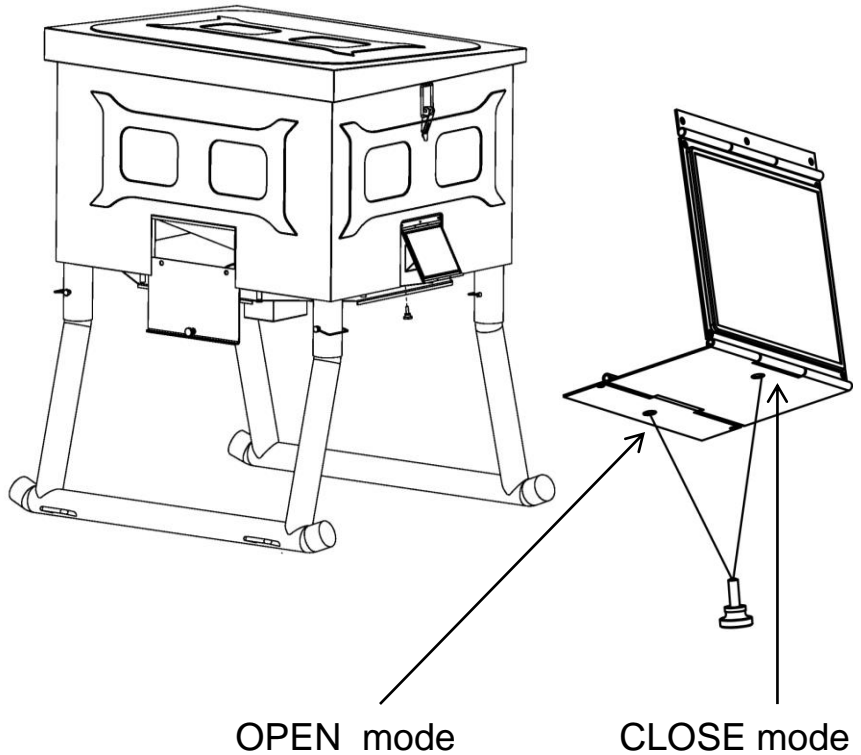

HOW TO LOAD YOUR FEEDER

OPEN THE LID AND POUR FEED INTO THE HOPPER. AFTER FILLING, CLOSE THE LID.

TIPS & POINTERS:

(Q) What kind of feed should I use?

(A) Whole kernel corn is recommended. Whole kernel corn mixed with soybeans or pellets is also effective for attracting deer. NOTE: When not mixed with corn, some types of pellets can take on moisture and clog the feeder.

Care and Maintenance

- **INSPECT FEEDER FOR ANY LOOSE PARTS OR HARWARE REGULARLY**
- **CHECK IF FEEDER IS TAKING WATER ON RAINY DAYS. SEAL GAP WITH SILICONE SEALANT IF NECESSARY**
- **IF RUST APPEARS ON THE EXTERIOR SURFACE OF FEEDER, CLEAN AND BUFF THE AFFECTED AREA WITH STEEL WOOL OR FINE GRIT EMERY CLOTH. TOUCH-UP WITH A GOOD QUALITY PAINT**
- **STORE FEEDER INDOORS WHEN NOT IN USE**
- **CLEAN FEEDER HOPPER REGULARLY TO AVOID CLOGGING AND DAMAGE TO THE CONTROL UNIT**

Replacement Parts

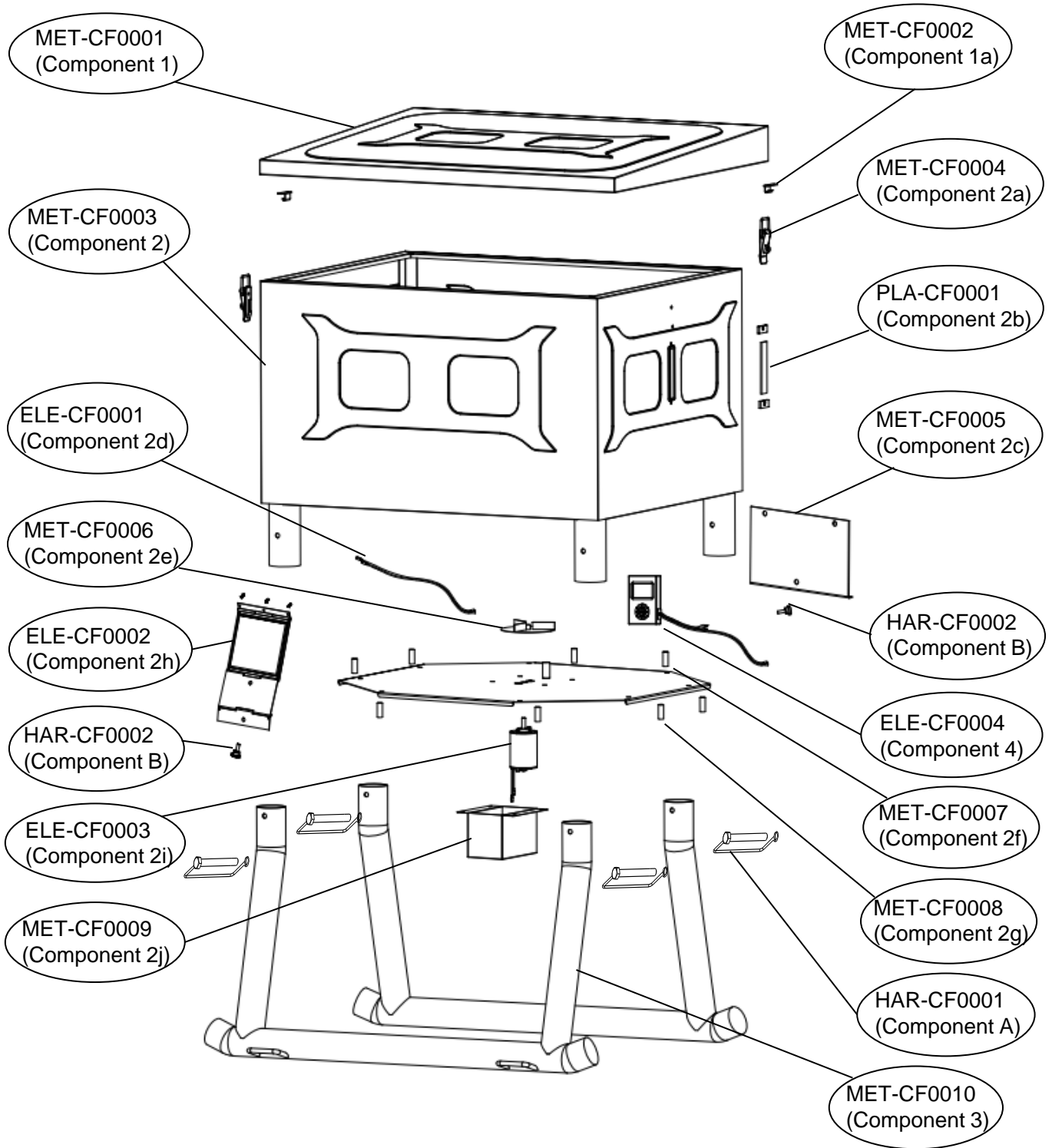

Replacement Parts

Part Number	Component	Part Name
MET-CF0001	1	Lid
MET-CF0002	1a	Catcher
MET-CF0003	2	Hopper
MET-CF0004	2a	Latch
PLA-CF0001	2b	Feed Window and Brackets
MET-CF0005	2c	Door
ELE-CF0001	2d	Wire Extender
MET-CF0006	2e	Spinner
MET-CF0007	2f	Varmint Plate
MET-CF0008	2g	Short Tubes
ELE-CF0002	2h	Solar Panel Charger
ELE-CF0003	2i	12V Motor
MET-CF0009	2j	Motor Box
MET-CF0010	3	Leg
ELE-CF0004	4	Digital Timer
HAR-CF0001	A	Lock Pin
HAR-CF0002	B	Bolt

Warranty Information

1. Manufacturer warrants this product to be free from defects in workmanship and materials for a period of 90 days from the date of purchase, PROVIDED claims are submitted, in writing, with proof of purchase.
2. If any part of this item fails because of a manufacturing defect within the Limited Warranty Period, manufacturer offers to replace such part(s) provided that such parts have not been improperly repaired, altered, or tampered with or subject to misuse, abuse, or exposed to corrosive conditions. This Limited Warranty is, however, subject to certain limitations, exclusions, time limits, and exceptions (hereinafter “conditions”) as listed below. Read these conditions carefully.
3. This Limited Warranty shall be limited to the replacement or repair of any part(s) which manufacturer determines, after reasonable examination, to have been defective at the time of manufacturing and manufacturer’s obligation(s) shall be limited to replacement, if any, of defective part(s) which shall be shipped at original purchaser’s expense to original purchaser’s designated shipping address.
4. This Limited Warranty is given to and covers the **ORIGINAL PURCHASER ONLY** and such coverage terminates 90 days from the date of purchase.
5. **DAMAGE LIMITATION WARNING:** IN NO EVENT SHALL MANUFACTURER BE LIABLE FOR ANY INCIDENTAL OR CONSEQUENTIAL DAMAGES, INCLUDING (BUT NOT LIMITED TO) LOSS OF USE OF THE PRODUCT, LOSS OF TIME, INCONVENIENCE, EXPENSES FOR TRAVEL, TRANSPORTATION, LODGING EXPENSES, LOSS OF FOOD, LOSS BY DAMAGE TO PERSONAL PROPERTY OR LOSS OF INCOME, PROFITS OR REVENUE.
6. **MANUFACTURER’S OBLIGATION:** Manufacturer’s liability shall be limited to the delivery of a good, merchantable product, and, if necessary, the repair or replacement, at manufacturer’s option, of any defective part or unit.
7. **TRANSFER LIMITATIONS:** This Limited Warranty is not assignable or transferable. It covers only the original purchaser.
8. **RESERVED RIGHT TO CHANGE:** Manufacturer reserves the right to make changes or improvements to products it produces in the future without imposing on itself any obligations to install the same improvements in the products it has previously manufactured.
9. This Limited Warranty gives the original purchaser specific legal rights, but there may be other rights which vary by jurisdiction.
10. **This warranty does not cover the following items:**
 - Chips or scratches on porcelain or painted surfaces
 - Rust or corrosion is not deemed a manufacturing or materials defect
 - Discoloration or loss of paint due to handling during assembly, heat, or cleaning products. Paint may require touch up.
 - Stainless steel discoloration or corrosion
 - Consumables such as batteries
 - Damages caused by wild game

Warranty Information

IF CUSTOMER SERVICE IS NECESSARY:

The original purchaser is responsible for shipping and handling charges of the returned item(s) and replacement parts, if any.

All parts to be replaced will need to be shipped before replacement items will be sent.

Follow the customer service representative's instructions exactly. If a return is necessary, it must be packed carefully and shipped prepaid.

Should you encounter any problems
obtaining replacement parts,
CALL US FIRST.

Do not return product to the store.
WE CAN HELP.

Rankam (China) Manufacturing Co. Ltd.
18/F., New Lee Wah Centre, 88 Tokwawan Road,
Kowloon, Hong Kong

Please contact Rankam Customer Service at
customerservice@rankam.com

or at 1-888-837-1380, Mon to Fri, 8:00 a.m. – 5:00 p.m. Pacific Standard Time.